

the Smoking Gun™

Instruction Book - BSM600



Sage® by heston
blumenthal™



Contents

- 2 Sage Recommends Safety First
- 6 Components
- 7 Assembly
- 8 Functions
- 9 Tips
- 10 Care & Cleaning
- 11 Troubleshooting

SAGE RECOMMENDS SAFETY FIRST

At Sage® by Heston Blumenthal® we are very safety conscious. We design and manufacture consumer products with the safety of you, our valued customer, foremost in mind. In addition we ask that you exercise a degree of care and adhere to the following precautions.

IMPORTANT SAFEGUARDS

READ ALL INSTRUCTIONS BEFORE USE AND SAVE FOR FUTURE REFERENCE

- Remove any packaging material and promotional labels before using the Smoking Gun™ for the first time.
- Do not place the Smoking Gun™ near the edge of a table, counter or bench top during operation. Ensure that the surface is level, clean and free of water.
- Do not place any part of the Smoking Gun™ in a gas, electric or microwave oven or on a hot gas or electric burner.
- Keep smoking gun clear of walls, curtains and other heat or steam sensitive materials. Minimum 200mm distance.

- Always ensure the Smoking Gun™ is properly assembled before use. Follow the instructions provided in this book.
- Do not leave the product unattended when in use.
- Do not touch hot surfaces.
- Do not use harsh abrasives or caustic cleaners when cleaning this product.
- Keep the product clean. Follow the care and cleaning instructions provided in this book.
- This product is not intended for use by persons (including children) with reduced physical, sensory or mental capabilities, or lack of experience and knowledge, unless they have been given supervision or instruction concerning use of the product by a person responsible for their safety.
- This product is intended for household use only. Do not use this product for anything other than its intended use. Do not use in moving vehicles or boats.
- It is recommended to regularly inspect the product.
- Any maintenance other than cleaning should be performed at an authorised Sage Service Centre.
- Do not attempt to burn anything other than small wood chips, wood sawdust, dried herbs, cooking spices, or tea leaves in the burn chamber.
- Do not leave the Smoking Gun™ unattended.

- Use only in a well ventilated area; the burning of wood chips/ dust, dried herbs, cooking spices, and/or tea leaves may result in the emission of combustion by-products which are known to cause cancer, birth defects, and/or reproductive harm.
- The metal barrel and burn chamber of the Smoking Gun™ will become very hot when in use. Allow device to cool completely before touching barrel or burn chamber, cleaning, or storing.
- Always use the Smoking Gun™ in an upright position. Heated smoking materials may fall out of the burn chamber if tipped, resulting in a fire hazard.
- Always empty ash and burnt material into a non-flammable receptacle.
- Exercise proper care when igniting the smoking materials; improper ignition of flammable materials may result in explosion or fire hazard.
- Always use a match or lighter to ignite the materials in the Smoking Gun™; DO NOT USE a kitchen torch or other heat device as the excessive heat may damage the unit.
- Do not point the Smoking Gun™ at any person or flammable object.
- Avoid using the Smoking Gun™ in areas where smoke may activate smoke alarms or fire suppression systems.

- Never operate the Smoking Gun™ without the stainless steel mesh filter in place; burning/glowing embers may enter the body damaging the unit or be ejected through the nozzle, creating a fire or burn hazard.
- Removal or disassembly of any parts of the Smoking Gun™ other than the burn chamber; stainless steel mesh filter, battery compartment cover, or batteries may result in irreparable damage and void the warranty.



The symbol shown indicates that this product should not be disposed of in normal household waste. It should be taken to a local authority waste collection centre designated for this purpose or to a dealer providing this service. For more information, please contact your local council office.

SAVE THESE INSTRUCTION



Components

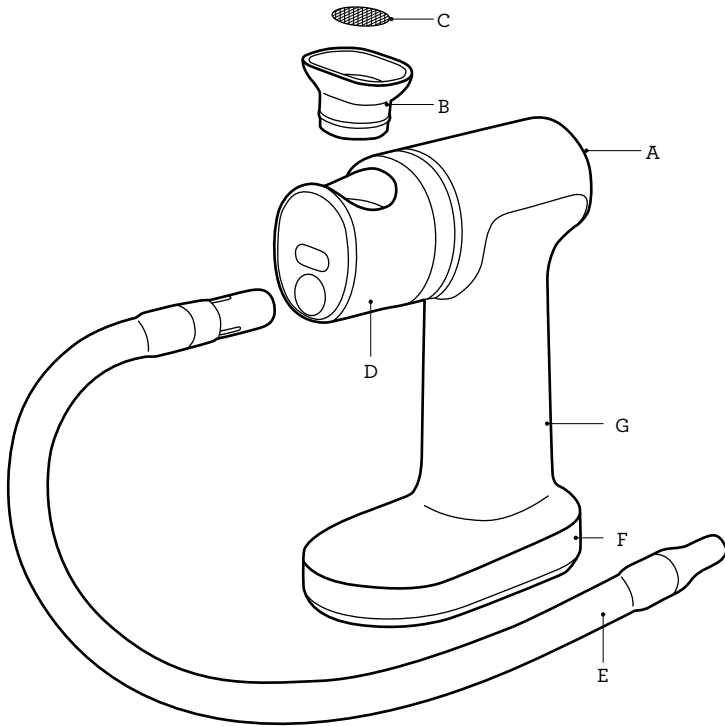

- A. **On/off switch**
With dual speed for ignition and slow burn.
- B. **Removable burn chamber**
Easy to tap out ash at the end of burn cycle.
- C. **Removable mesh filter**
Push out with finger to replace.
- D. **Die-cast barrel**
- E. **Silicone hose**
- F. **Robust housing**
Integrated base provides stable secure platform.
- G. **Battery operated**
Uses 4 x AA 1.5V battery.



Assembly

1. Place the mesh filter in the top of the burn chamber and press down with a finger to seat it into the bottom of the burn chamber.
2. Place the burn chamber into the barrel. Push down until the spring around the burn chamber provides a small click sensation.



3. Press the larger plastic end on the silicone hose firmly into the round hole on the front of the barrel.

BATTERIES

Use 4 x AA (1.5V alkaline) batteries only.
(No rechargeable batteries)

1. Remove battery cover from underside of unit by sliding clip towards rear and rotating outwards.
2. Insert batteries into cavity with orientation to match the outer face of the battery cover.
3. Replace battery cover and press to snap into place.



Functions

BEFORE FIRST USE

Remove any packaging material and promotional labels from the Smoking Gun™.

Wipe the burn chamber and mesh filter with a damp cloth.

OPERATION

1. Place a small amount of wood chips (or desired smoking materials) into the burn chamber.



NOTE

Do not overfill the burn chamber. The wood chips should just cover the mesh filter area with a thin layer.

2. Press down the power switch located on the rear of the main unit, to activate the fan at high speed. This position is designated by 2 lines = on the switch.

- Low Speed	O Off	= High Speed
To smoulder the wood chips and generate smoke.		For greater airflow to assist in initially igniting wood chips.

3. Use a handheld lighter or match to apply a flame to the top surface of the wood chips. Move the flame around to ignite the entire exposed surface. For best results make sure the burning area is evenly distributed or centred.



WARNING

- Do not use a kitchen torch or butane torch style lighter.
 - Maintain the presence of the lighter for a period of time sufficient to start ignition only. Excessive heat may cause damage to the unit.
4. Once the smoke is seen exiting the end of the hose, depress the top of the switch to maintain the fan on low speed (designated by 1 line -). Allow the wood chips to smoulder and direct the smoke to where required (see Tips page 9).
 5. When sufficient smoke has been generated or wood chips are extinguished, return the switch the central position to turn the fan off (designated by a circle O).
 6. Allow the unit to cool completely after burning has completed.
 7. When cooled completely the burn chamber can be removed by pulling it free of the barrel.



NOTE

- Invert the burn chamber and tap on a solid surface to remove any remaining wood chips or ash.
- It is recommended to clean the burn chamber prior to re-assembly.



WARNING

The burn chamber is very hot after use. Exercise caution.



Tips

- To provide smoke flavour and aroma for meats, fish, fruits, or vegetables after cooking, simply place the food in a covered casserole, stockpot, Dutch oven, or other covered dish/pan and inject smoke under the lid. (See below table for smoking techniques. See recipe cards included separately for more ideas and details.)
- To enhance the presentation of a finished dish, add a hint of smoke under a domed plate cover.
- Use the Smoking Gun™ to infuse delicate foods, such as cheeses and vegetables, with smoky flavour and aroma without changing their texture.
- One to three minutes under smoke is generally all that is needed to infuse foods with a smoky flavour and aroma. When using the Smoking Gun™ with a covered receptacle, simply inject the smoke under the lid and let stand for a few minutes.
- Don't place hose directly in the food. Place it just slightly above.
- Continuous smoking with the Smoking Gun™ is NOT required.
- Ensure the unit has had sufficient time to cool before reloading and operating additional burn cycles if required.
- Hickory chips impart a pungent, smoky bacon-like flavour that goes particularly well with most meats, especially pork (ham, ribs, etc.) and beef. They are good for most vegetables because they impart a strong earthy flavour.
- Applewood chips work well with poultry, game birds and pork. These woods provide a slightly sweet but denser, fruity smoke flavour.
- Use wood chips that have been specifically prepared for the purpose of smoking - these timbers will have been dried to the correct level and will produce less resinous materials in the smoke output from the unit.

TECHNIQUES

CONTAINER OR BAG	<ol style="list-style-type: none"> 1. When smoking cooked foods, apply smoke after cooking. 2. Place food in a container, cover with plastic wrap, insert tube and fill with smoke. Alternatively, place food in sealable bag, insert tube and fill bag with smoke. 3. Let food absorb smoke for 1-3 minutes and repeat 2-3 times for a stronger smoke flavour.
TABLESIDE	<ol style="list-style-type: none"> 1. Plate food for serving. 2. Hold drinking glass upside down and fill with smoke. 3. Place glass over food and let smoke absorb while serving. 4. Lift glass at table in front of your guests.
STAND MIXER	<ol style="list-style-type: none"> 1. Whip or beat food in a stand mixer. 2. Spread food evenly on mixing bowl walls for maximum surface area. 3. Cover mixing bowl with plastic wrap, insert tube and fill with smoke. 4. Let food absorb smoke for 1 minute and repeat 2-3 times for a stronger smoke flavour.
SHAKER	<ol style="list-style-type: none"> 1. Prepare beverage. 2. Fill shaker with smoke, remove tube, cover with lid and shake.



Care & Cleaning

1. Before cleaning, make sure the unit is completely cooled down and power switch is positioned to off position.
2. Remove the burn chamber from the barrel. Invert the burn chamber and tap on a solid surface to remove any remaining wood chips or ash. The burn chamber may be cleaned by hand with warm soapy water or by placing in a dishwasher.
3. Wipe the barrel clean if residue is visible.
4. Mesh filter can be cleaned with warm soapy water and small brush as required.
5. Clean hose and tube ends in warm soapy water as required.
6. Use damp cloth to clean the main unit. Do not immerse in water.



NOTE

- Do not use unit without the burn chamber present.
- Do not use unit if there is no mesh filter in the burn chamber.
- Cannot be used to bubble through liquid – the fan/motor is not strong enough.
- Hose can be stored in loop to contain smell.
- Remove the batteries if the device is not to be used for a long period of time.
- Allow the unit to cool completely between consecutive burns.



NOTE

Replace mesh filter if it becomes clogged.

Filter specification:

No.20 US Sieve Size [Ø19.0mm (¾ inch), stainless steel 304].



WARNING

Resin may stain hands, handle parts with caution.

Visit www.sageappliances.co.uk or www.breville.com to order more wood chips.



Troubleshooting

POSSIBLE PROBLEM**EASY SOLUTION**

Fan not starting.

- Check orientation of batteries.
 - Switch not turned to High or Low speed.
 - Replace batteries.
-

No smoke generated.

- Ensure mesh filter is not blocked.
 - Ensure the hose is not blocked.
 - When using a container ensure there is an outlet for the air to escape.
 - Ensure the fan starts when the switch is pressed to High or Low.
 - Ensure wood chips are dry and small.
 - Increase fan speed to High.
-

Not enough smoke.

- Turn fan to High Speed to increase burn rate.
-

Sage® by Heston Blumenthal®

Freephone (UK Landline): 0808 178 1650
Mobile Calls (National Rate): 0333 0142 970

www.sageappliances.co.uk
customerservice@sageappliances.co.uk

Register your product and get more from your purchase

Product registration takes only a few minutes and ensures a record of your purchase. Registration also makes it easier to get support and advice on any questions or issues that you might have in the future. If you wish, we can also send you free recipes and additional hints and tips on making the best of your appliance.

➤ Go to www.sageappliances.co.uk and click on 'Product Registration'.

What's on your mind?

Our constant aim is to improve the quality and features of our appliances. We welcome your comments and ideas in assisting our ongoing development.

➤ Go to www.sageappliances.co.uk and click on 'Support'.

Sage® by heston
blumenthal®

Registered in England & Wales No. 8223512. Due to continued product improvement, the products illustrated or photographed in this document may vary slightly from the actual product.

Copyright BRG Appliances 2016.

BSM600 UKM – A16